

90° Band / CFS - Backshell A17-863-

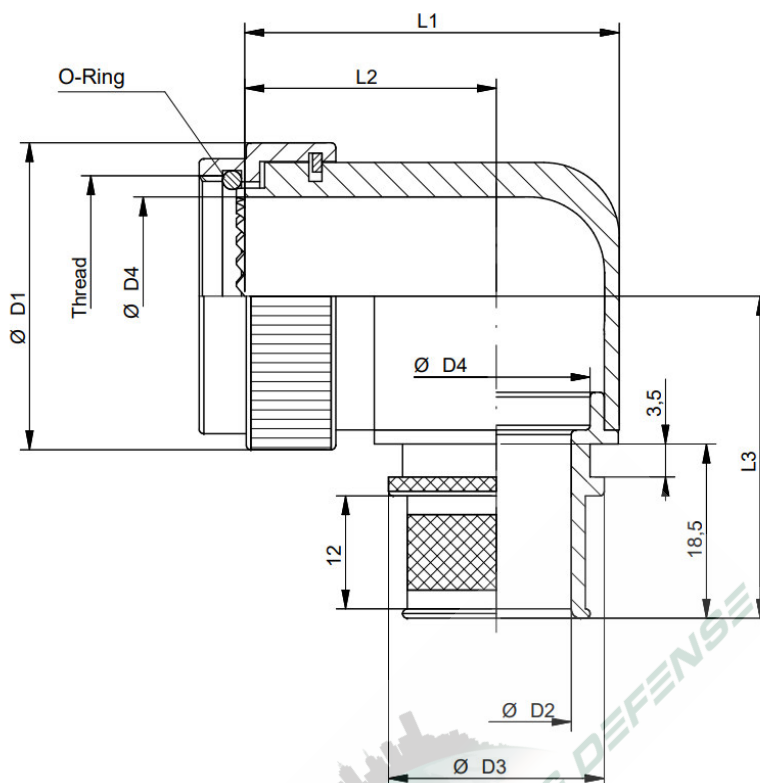

Applications:

- Termination of screened and braided cables / also suitable for double screened cables.
- For high level shielding effectiveness.

Example: **A17-863- 4 5 08**

Basic part number

Shell size code

Plating finish

Entry size

Table 1 Shell size code / basic part number

Basic Part number	Shell size	ØD1 max	ØD4 min	L1 max	L2 ±0,5	L3 max	Thread size
A17-863-1	08	19,0	7,0	25,5	17,5	30,3	7/16-28 UNEF
A17-863-2	10	22,0	9,5	28,5	18,5	32,0	9/16-24 UNEF
A17-863-3	12	25,0	13,3	32,0	20,5	33,5	11/16-24 UNEF
A17-863-4	14	28,0	15,7	35,5	22,5	35,0	13/16-20 UNEF
A17-863-5	16	30,0	18,8	38,5	24,0	36,8	15/16-20 UNEF
A17-863-6	18	34,0	21,2	42,0	26,0	38,5	1 1/16-18 UNEF
A17-863-7	20	38,0	24,4	45,5	28,0	41,0	1 3/16-18 UNEF
A17-863-8	22	43,0	27,6	48,5	29,5	41,5	1 5/16-18 UNEF
A17-863-9	24	45,0	30,8	51,5	31,0	43,0	1 7/16-18 UNEF

Table 2: Entry size

Entry size code	ØD2 min	ØD3 max
03	4,7	13,9
04	6,3	13,9
05	7,9	15,5
06	9,5	17,2
07	11,1	18,7
08	12,7	20,3
09	14,2	21,9
10	15,8	23,5
11	17,4	25,1
12	19,0	26,7
13	20,6	28,3
14	22,2	29,9
15	23,8	31,5
16	25,4	33,1
17	27,0	34,7
18	28,6	36,3
19	30,2	37,9
20	31,8	39,5
21	33,3	41,1
22	35,0	42,7
23	36,5	44,3
24	38,1	45,9

Table 3: Material & Plating options

Material & Plating code	Plating finish	Electrically conductive	ROHS-/REACH Compatible
J	Black Hybrid finish Base material: Aluminium alloy Coupling Ring: Anodized, black Screen termination system: Electrically conductive (Nickel plating) All visible parts: Black coated in assembled condition. 500h salt spray resistance Version *J* is intermatable with Cadmium-, Nickel-, Zinc-Nickel-, and Zinc-Cobalt plated Connectors	YES	YES
U	Olive drab Hybrid finish Base material: Aluminium alloy Coupling Ring: Anodized, olive drab Screen termination system: Electrically conductive (Nickel plating) All visible parts: Olive drab coated in assembled condition. 500h salt spray resistance Version *U* is intermatable with Cadmium-, Nickel-, Zinc-Nickel-, and Zinc-Cobalt plated Connectors	YES	YES
5	Electroless nickel Base material: Aluminium alloy 48h salt spray resistance	YES	YES
2	Zinc-Nickel black Base material: Aluminium alloy Shell: Zinc-Nickel black Coupling Ring: Anodized, black 500h salt spray resistance	YES	YES
6	Cadmium olive drab Base material: Aluminium alloy Shell: Cadmium olive drab over electroless nickel Coupling Ring: Anodized, olive drab 500h salt spray resistance	YES	NO

All dimensions in mm