

**45° Band / CFS-Adapter**  
**45° Band / CFS- Backshell**  
**A87-570- \_ \_ \_ \_**

Für Steckverbinder nach Serien / *To suit connectors to series:*

**MIL-DTL-26482 Series II**

**MIL-DTL-83723 Series III**

**MIL-DTL-5015** *with crimp rear release contacts (MS345x)*

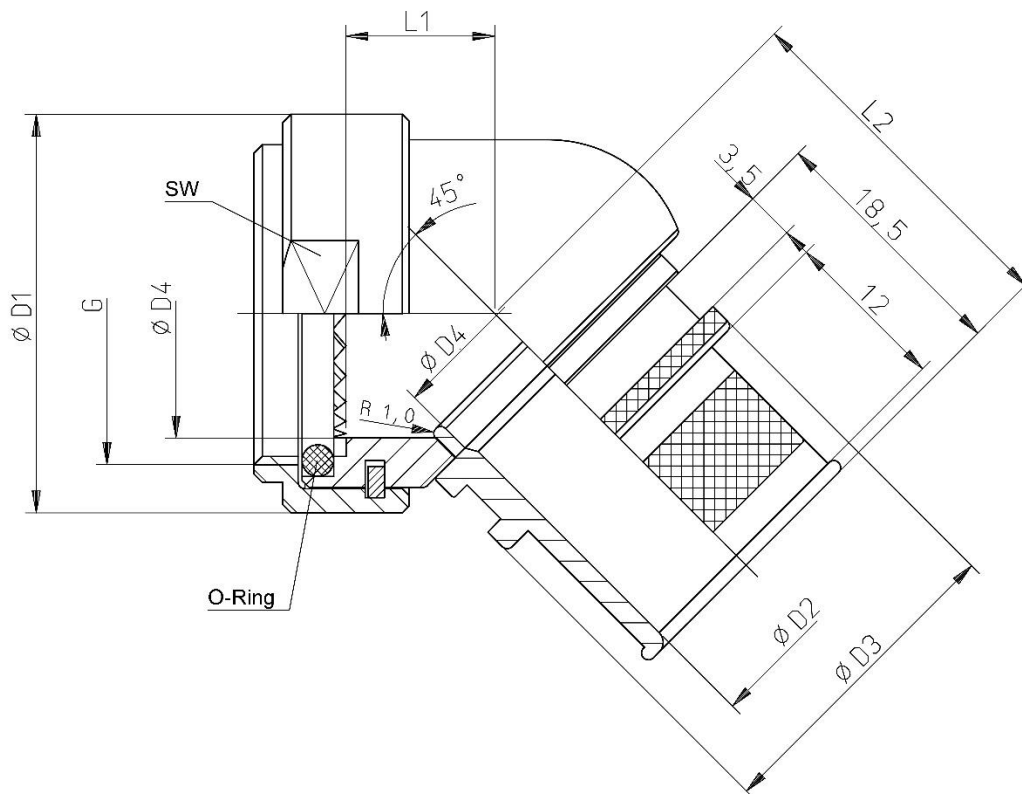

Anwendung / *Applications:*

- Anschluss von geschirmten Kabeln / *Termination of screened and braided cables*
- Auch geeignet für Kabel mit doppeltem Schirmgeflecht / *Also suitable for double screened cables*
- Für hohe Schirmwirkung / *For high level shielding effectiveness*

**Bestellbeispiel**

***How to order***

Artikelbezeichnung / *Basic part number*

Gehäusegröße Kennziffer / *Shell size code*

Material- & Oberflächenausführung / *Material- & Plating option*

Kabeleingangsdurchmesser / *Cable entry size*

**Tabelle**  
***Table***

1  
1  
3  
2

**A87-570-4 5 08**

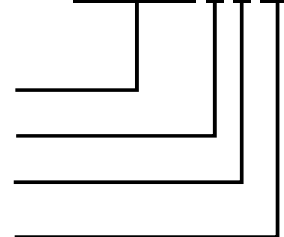

**Tabelle 1: Artikelbezeichnung und Gehäusegröße**  
**Table 1: Basic part number and shell size**

Artikelbezeichnung und Gehäusegröße Kennziffer	Gehäuse- größe	Ø D1 +/-0,2	Ø D4 min	L1 max	L2 max	G	SW	ADM
						Gewinde <i>Thread</i>	Schlüssel -weite	empfohlenes Anzugsdreh- moment <b>Nm</b>
<i>Basic part number and shell size code</i>	<i>Shell size</i>					UNEF-2B	<i>Spanner size</i>	Recommended fastening torque <b>Nm</b>
<b>A87-570-1</b> _____	08	19,0	7,5	13,0	26,0	1/2-20	17	4
<b>A87-570-2</b> _____	10	22,0	10,5	13,5	27,0	5/8-24	20	6
<b>A87-570-3</b> _____	12	25,0	13,5	14,0	27,0	3/4-20	23	8
<b>A87-570-4</b> _____	14	29,0	17,5	14,0	28,0	7/8-20	27	10
<b>A87-570-5</b> _____	16	32,0	20,0	15,0	29,0	1-20	30	10
<b>A87-570-6</b> _____	18	34,0	23,0	16,0	29,5	1 1/16-18	32	13
<b>A87-570-7</b> _____	20	38,0	26,0	17,0	30,0	1 3/16-18	36	13
<b>A87-570-8</b> _____	22	43,0	29,0	17,5	30,5	1 5/16-18	41	13
<b>A87-570-9</b> _____	24	45,0	32,0	18,0	31,5	1 7/16-18	43	13

Alle Maßangaben in mm  
*All dimensions in mm*

**Tabelle 2: Kabeleingangsdurchmesser**  
**Table 2: Cable entry sizes**

Kabeleingang <i>Entry size code</i>	Ø D2 +0,3	Ø D3 max	Kabeleingang <i>Entry size code</i>	Ø D2 +0,3	Ø D3 max	Kabeleingang <i>Entry size code</i>	Ø D2 +0,3	Ø D3 max
<b>03</b>	4,7	13,9	<b>11</b>	17,4	25,1	<b>19</b>	30,2	37,9
<b>04</b>	6,3	13,9	<b>12</b>	19,0	26,7	<b>20</b>	31,8	39,5
<b>05</b>	7,9	15,5	<b>13</b>	20,6	28,3	<b>21</b>	33,3	41,1
<b>06</b>	9,5	17,2	<b>14</b>	22,2	29,9	<b>22</b>	35,0	42,7
<b>07</b>	11,1	18,7	<b>15</b>	23,8	31,5	<b>23</b>	36,5	44,3
<b>08</b>	12,7	20,3	<b>16</b>	25,4	33,1	<b>24</b>	38,1	45,9
<b>09</b>	14,2	21,9	<b>17</b>	27,0	34,7			
<b>10</b>	15,8	23,5	<b>18</b>	28,6	36,3			

Alle Maßangaben in mm  
*All dimensions in mm*

**Tabelle 3: Material und Oberflächenausführung**  
**Table 3: Material and Plating option**

Material & Oberfläche <b>Kennung</b> <i>Material &amp; Plating Code</i>	Technische Ausführung und Beschreibung	<i>Technical design and description</i>	ROHS-/REACH Konform <i>Compatible</i>	Elektrisch leitend <i>Electrically conductive</i>
<b>J</b>	<p><b>Hybrid schwarz</b></p> <ul style="list-style-type: none"> <li>- Kuppel-Mutter: Al- Legierung, schwarz anodisiert</li> <li>- Gehäuse: Al- Legierung, chemisch vernickelt und im Außenbereich selektiv schwarz beschichtet</li> <li>- Schirmanschlusssystem ist sehr gut elektrisch leitend (chemisch Nickel)</li> <li>- Alle sichtbaren Teile sind im zusammengebauten Zustand schwarz eingefärbt</li> <li>- Salznebelbeständigkeit: <ul style="list-style-type: none"> <li>• 500 h nach MIL Spezifikation</li> <li>• 5 d zyklisch nach VG Spezifikation</li> </ul> </li> <li>- Version *J* ist kompatibel mit Cadmium-, Nickel-, Zink-Nickel-, und Zink-Cobalt beschichteten Steckverbindern</li> </ul>	<p><b>Black Hybrid finish</b></p> <ul style="list-style-type: none"> <li>- <i>Coupling Ring: Al- alloy, black anodized</i></li> <li>- <i>Shell: Electroless nickel plating, exposed area is selective black coated</i></li> <li>- <i>Screen termination system has a very good electrical conductivity (electroless nickel)</i></li> <li>- <i>All visible parts are black coloured in assembled condition</i></li> <li>- <i>Salt spray resistance:</i> <ul style="list-style-type: none"> <li>• 500 hrs according to MIL spec.</li> <li>• 5 d cyclic according to VG spec.</li> </ul> </li> <li>- <i>Version *J* is intermateable with Cadmium-, Nickel, Zinc-Nickel-, and Zinc-Cobalt plated Connectors</i></li> </ul>	JA YES	JA YES
<b>5</b>	<p><b>Stromlos vernickelt</b></p> <ul style="list-style-type: none"> <li>- Basismaterial: Al- Legierung</li> <li>- Salznebelbeständigkeit: <ul style="list-style-type: none"> <li>• 48 h nach MIL Spezifikation</li> </ul> </li> </ul>	<p><b>Electroless nickel</b></p> <ul style="list-style-type: none"> <li>- <i>Base material: Al- alloy</i></li> <li>- <i>Salt spray resistance:</i> <ul style="list-style-type: none"> <li>• 48 hrs according to MIL spec.</li> </ul> </li> </ul>	JA YES	JA YES
<b>2</b>	<p><b>Zink-Nickel schwarz</b></p> <ul style="list-style-type: none"> <li>- Kuppel-Mutter: Al- Legierung, schwarz anodisiert</li> <li>- Gehäuse: Al- Legierung, Zink – Nickel schwarze Beschichtung über chem. Nickel</li> <li>- Salznebelbeständigkeit: <ul style="list-style-type: none"> <li>• 500 h nach MIL Spezifikation</li> </ul> </li> </ul>	<p><b>Zinc-Nickel black</b></p> <ul style="list-style-type: none"> <li>- <i>Coupling Ring: Al- alloy, black anodized</i></li> <li>- <i>Shell: Zinc – Nickel black chromate over electroless nickel</i></li> <li>- <i>Salt spray resistance:</i> <ul style="list-style-type: none"> <li>• 500 hrs according to MIL spec.</li> </ul> </li> </ul>	JA YES	JA YES
<b>6</b>	<p><b>Cadmium olivgrün chromatiert</b></p> <ul style="list-style-type: none"> <li>- Kuppel-Mutter: Al- Legierung, bronzoliv anodisiert</li> <li>- Gehäuse: Al- Legierung, cadmiert und olivgrün chromatiert über chemisch Nickel</li> <li>- Salznebelbeständigkeit: <ul style="list-style-type: none"> <li>• 500 h nach MIL Spezifikation</li> <li>• 5 d zyklisch nach VG Spezifikation</li> </ul> </li> </ul>	<p><b>Cadmium olive drab</b></p> <ul style="list-style-type: none"> <li>- <i>Coupling Ring: Al- alloy, olive drab anodized</i></li> <li>- <i>Shell: Al- alloy cadmium plated olive drab over electroless nickel</i></li> <li>- <i>Salt spray resistance:</i> <ul style="list-style-type: none"> <li>• 500 hrs according to MIL spec.</li> <li>• 5 d cyclic according to VG spec.</li> </ul> </li> </ul>	NEIN NO	JA YES
<b>9</b>	<p><b>Marinebronze</b></p> <ul style="list-style-type: none"> <li>- Keine weitere Oberflächenbehandlung</li> </ul>	<p><b>Marine Bronze</b></p> <ul style="list-style-type: none"> <li>- <i>No additional plating</i></li> </ul>	JA YES	JA YES
<b>1</b>	<p><b>Edelstahl-nichtrostend / passiviert</b></p>	<p><b>Stainless Steel / passivated</b></p>	JA YES	JA YES