

Protective Cap for Receptacles:

C39-644- _ _

To suit jam nut connector receptacles to series: MIL-C38999

Serie III; JN1034; CECC75-201-002; EN3645-001;

BS9520G0003; VG95319-100x

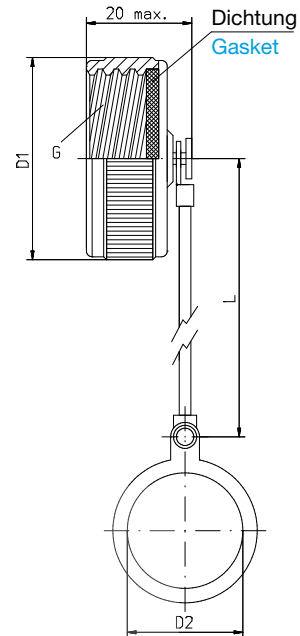

Größe: Shell Size:	EMCA Teile-Nr. Part No.	D1 max	D2 min	G Gewinde Thread Size Class 2B 0.1P-0.3L-TS	L +12,7 -6,35
9	C39-644-0x1	22,86	17,64	0.6250	127
11	C39-644-0x2	27,96	21,97	0.7500	127
13	C39-644-0x3	30,48	25,12	0.8750	127
15	C39-644-0x4	31,75	29,92	1.0000	127
17	C39-644-0x5	36,83	32,00	1.1875	127
19	C39-644-0x6	38,10	36,27	1.2500	127
21	C39-644-0x7	41,91	38,25	1.3750	127
23	C39-644-0x8	44,45	42,62	1.5000	127
25	C39-644-0x9	48,26	44,45	1.6250	127

Maße in mm/Dimensions in mm

X in EMCA Teile-Nr. X in Part No.	Basismaterial Base Material	Oberflächenbehandlung Plating finish	Seil-Material Rope Material
C39-644-*5*	Aluminium Legierung Aluminum alloy	Stromlos vernickelt Electroless nickel	Draht-schwarz ummantelt Wire-black jacketed
C39-644-*6*	Aluminium Legierung Aluminum alloy	Cd grün chromatiert Cadmium olive drab	Draht-schwarz ummantelt Wire-black jacketed
C39-644-*9*	Marine Bronze Marine Bronze	-	Draht-schwarz ummantelt Wire-black jacketed

Please contact the factory for other available plating finishes and materials

Material and Plating Finish Specification

Material und Oberflächenbehandlung	Material and Plating Finish	Kennzeichnung Code	RoHS konform Compliant
Edelstahl passiviert, rostfrei elektrisch leitend salzsprühfest	Stainless steel passivated electrically conductive salt spray resistant	xxx-xxx-x1x	ja yes
Aluminium ZnNi schwarz chromatiert elektrisch leitend min. 500h salzsprühfest	Aluminum ZnNi black chromate electrically conductive min. 500hr salt spray resistant	xxx-xxx-x2x	ja yes
Aluminium schwarz eloxiert elektrisch nicht leitend 96h salzsprühfest	Aluminum black anodized electrically non-conductive 96hr salt spray resistant	xxx-xxx-x3x	ja yes
Aluminium stromlos vernickelt elektrisch leitend min. 48h salzsprühfest	Aluminum electroless nickel electrically conductive min. 48hr salt spray resistant	xxx-xxx-x5x	ja yes
Aluminium cadmiert und grün chromatiert elektrisch leitend min. 500h salzsprühfest	Aluminum cadmium olive drab electrically conductive min. 500hr salt spray resistant	xxx-xxx-x6x	nein no
Aluminium Heavy Nickel min. 96h salzsprühfest	Aluminum Heavy Nickel min. 96hr salt spray resistant	xxx-xxx-x8x	ja yes
Marine Bronze elektrisch leitend salzsprühfest	Marine Nickel Aluminum Bronze electrically conductive salt spray resistant	xxx-xxx-x9x	ja yes

Please contact the factory for other available plating finishes.