

**Protective Cap for Plugs:
C19-688- _ _ _**

To suit connector plugs to series:
VG95328; MIL-DTL-26482 Series I&II

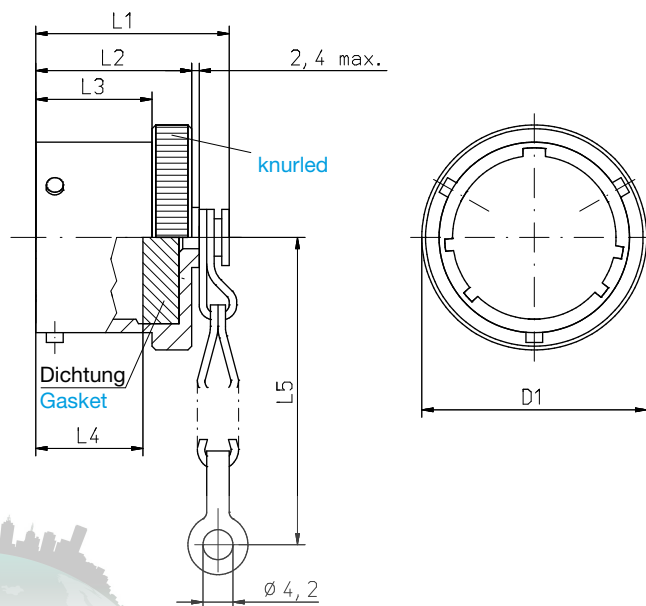

BOURNE AEROSPACE & DEFENSE

Sash chain DIN 5279-A0,5x18-1.4016 or equivalent

Größe: Shell Size:	EMCA Teile-Nr. Part No.	D1 max	L1 max	L2 max	L3 +0,8	L4 +0,25 -0,5	L5 +13 -7
8	C19-688-0x1	18,3	19,9	14,3	9,35	8,3	77
10	C19-688-0x2	21,5	19,9	14,3	9,35	8,3	77
12	C19-688-0x3	25,4	19,9	14,3	9,35	8,3	89
14	C19-688-0x4	28,6	19,9	14,3	9,35	8,3	89
16	C19-688-0x5	31,8	19,9	14,3	9,35	8,3	89
18	C19-688-0x6	35,0	19,9	14,3	9,35	8,3	89
20	C19-688-0x7	38,1	21,5	15,9	10,92	9,9	102
22	C19-688-0x8	41,3	21,5	15,9	10,92	9,9	102
24	C19-688-0x9	44,5	22,3	16,7	11,76	9,9	102

Maße im mm/Dimensions in mm

X in EMCA Teile-Nr. X in Part No.	Basismaterial Base Material	Oberflächenbehandlung Plating finish
C19-688-*5*	Aluminium Legierung Aluminum alloy	Stromlos vernickelt Electroless nickel
C19-688-*6*	Aluminium Legierung Aluminum alloy	Cd grün chromatiert Cadmium olive drab

Please contact the factory for other available plating finishes

Material and Plating Finish Specification

Material and Plating Finish	Code	RoHS Compliant
Stainless steel passivated electrically conductive salt spray resistant	xxx-xxx-x1x	ja yes
Aluminum ZnNi black chromate electrically conductive min. 500hr salt spray resistant	xxx-xxx-x2x	ja yes
Aluminum black anodized electrically non-conductive 96hr salt spray resistant	xxx-xxx-x3x	ja yes
Aluminum electroless nickel electrically conductive min. 48hr salt spray resistant	xxx-xxx-x5x	ja yes
Aluminum cadmium olive drab electrically conductive min. 500hr salt spray resistant	xxx-xxx-x6x	nein no
Aluminum Heavy Nickel min. 96hr salt spray resistant	xxx-xxx-x8x	ja yes
Marine Nickel Aluminum Bronze electrically conductive salt spray resistant	xxx-xxx-x9x	ja yes

Please contact the factory for other available plating finishes.