

Band / CFS - Backshell
A37-866-_____

To suit connectors to series: MIL-DTL-38999 Series III & IV

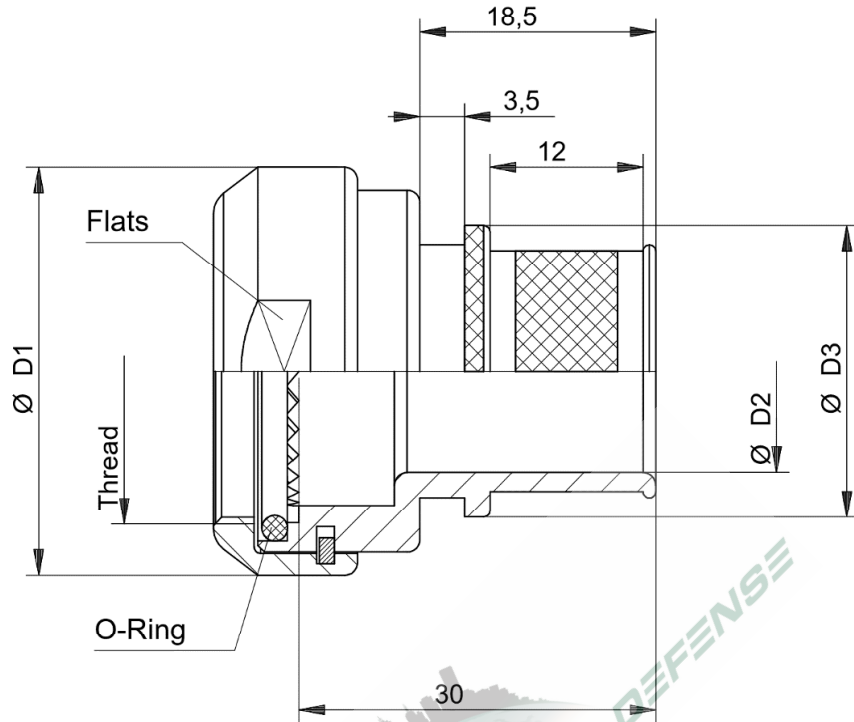

Applications:

- Termination of screened and braided cables / also suitable for double screened cables.
- For high level shielding effectiveness.

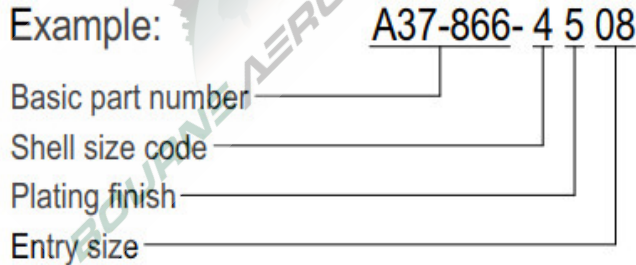

Table 1 Shell size code / basic part number

Basic Part number	Shell size	ØD1 max	Thread size	Flats Spanner size	Recommended Fastening torque Nm
A37-866-1	09 (A)	19,0	M12x1	17	5
A37-866-2	11 (B)	22,0	M15x1	20	5
A37-866-3	13 (C)	25,0	M18x1	23	8
A37-866-4	15 (D)	29,0	M22x1	27	8
A37-866-5	17 (E)	32,0	M25x1	30	10
A37-866-6	19 (F)	36,0	M28x1	34	10
A37-866-7	21 (G)	39,0	M31x1	37	11
A37-866-8	23 (H)	43,0	M34x1	41	12
A37-866-9	25 (J)	46,0	M37x1	44	13

Table 2: Entry size

Entry size code	ØD2 +0,3	ØD3 max
03	4,7	13,9
04	6,3	13,9
05	7,9	15,5
06	9,5	17,2
07	11,1	18,7
08	12,7	20,3
09	14,2	21,9
10	15,8	23,5
11	17,4	25,1
12	19,0	26,7
13	20,6	28,3
14	22,2	29,9
15	23,8	31,5
16	25,4	33,1
17	27,0	34,7
18	28,6	36,3
19	30,2	37,9
20	31,8	39,5
21	33,3	41,1
22	35,0	42,7
23	36,5	44,3
24	38,1	45,9

Table 3: Material & Plating options

Material & Plating code	Plating finish	Electrically conductive	ROHS-/REACH Compatible
J	Black Hybrid finish Base material: Aluminium alloy Coupling Ring: Anodized, black Screen termination system: Electrically conductive (Nickel plating) All visible parts: Black coated in assembled condition. 500h salt spray resistance Version *J* is intermatable with Cadmium-, Nickel-, Zinc-Nickel-, and Zinc-Cobalt plated Connectors	YES	YES
U	Olive drab Hybrid finish Base material: Aluminium alloy Coupling Ring: Anodized, olive drab Screen termination system: Electrically conductive (Nickel plating) All visible parts: Olive drab coated in assembled condition. 500h salt spray resistance Version *U* is intermatable with Cadmium-, Nickel-, Zinc-Nickel-, and Zinc-Cobalt plated Connectors	YES	YES
5	Electroless nickel Base material: Aluminium alloy 48h salt spray resistance	YES	YES
2	Zinc-Nickel black Base material: Aluminium alloy Shell: Zinc-Nickel black Coupling Ring: Anodized, black 500h salt spray resistance	YES	YES
6	Cadmium olive drab Base material: Aluminium alloy Shell: Cadmium olive drab over electroless nickel Coupling Ring: Anodized, olive drab 500h salt spray resistance	YES	NO
9	Marine Bronze (no additional plating)	YES	YES
1	Stainless Steel / passivated	YES	YES

All dimensions in mm